

CP Series Hydraulic Condensate Pots are designed and configured in six layouts. Refer to POT Configuration.

DK-LOK "CP" Series HYDRAULIC CONDENSATE POT

"CP" series Condensate Pot Part Listing

1	PIPE
2	CAP
3	HALF COUPLING (CHC)
4	VENT PLUG (CVP)
5	HEX HEAD PLUG (CHP)
6	SOCKET WELDING HALF COUPLING (CHCSW)

Table of Dimensions

Unit: mm

PIPE	D ANSI Pipe	L	L1*	L2
3"	88.9	214	110	50
4"	114.3	360	229	63.5

* L1 length is adjustable to fit client's requirements.

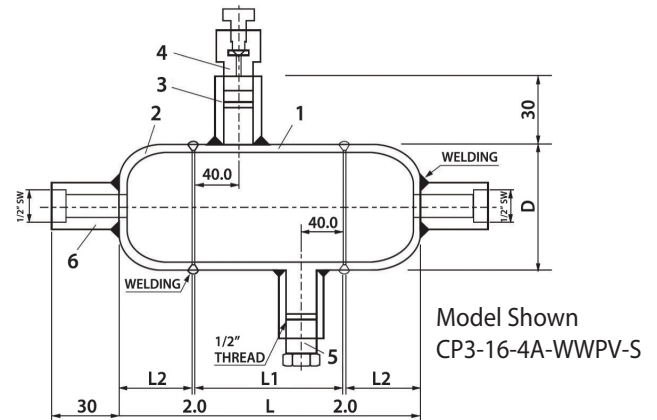

Ordering Information

To order CP Series, prefix "CP" and build up an ordering number by combining the designators in the sequence below. An example of ordering number: CP3 or CPJ3-16-4A-WWPV-S

CP3 or CPJ3

-16

-4A

-WWPV

-S

ANSI Pipe Designator

Designator	Pipe OD
2	2" ANSI 60.32 mm
3	3" ANSI 88.90 mm
4	4" ANSI 114.30 mm

JIS Pipe Designator

Designator	Pipe OD
J2	2" JIS 60.5 mm
J3	3" JIS 89.1 mm
J4	4" JIS 114.3 mm

Pipe Schedule

Designator	Pipe SCH
4	SCH40
8	SCH 80
16	SCH 160
X	SCH XXS

POT Configuration

Designator	Configuration
2A	
2B	
3A	
3B	
3C	
4A	

POT End Connections

End connectors are described by first the run (1 and 2) and next the branch (3 and 4).	End Connection	Designator
	1/2" NPT Female	N
	1/2" PT Female	R
	1/2" SW Socket Weld	W
	1/2" DK-LOK	D
	Vent Plug (CVP)	V
	Hex head plug (CHP)	P

* Fitting Class on end connection is selected as per the Pipe Schedule Rating.

Pipe Material

MATERIAL	Designator
ASTM A312-TP304	4
ASTM A312-TP304L	4L
ASTM A312-TP316	S
ASTM A312-TP316L	L
ASTM A335-P11	C11
ASTM A335-P22	C22
ASTM A106 Grade B	CB