

### DK63, DK10 SS Case Gauge with SS System



#### FEATURES

- All SS welded construction
- Zero Zone pointer indication
- Ventable plug
- MSL helium leak tested to  $1 \times 10^{-6}$  ATM - cc/sec
- RoHS compliant
- CRN approved
- 1 year limited warranty
- Exceeds ASME B40.100 grade B accuracy

#### PRODUCT SPECIFICATIONS

Type No.:	DK63, DK10										
Sizes:	63mm, 100mm										
Case:	304 SS										
Ring:	304 SS crimped										
Window:	Polycarbonate										
Dial:	Black figures on white background, aluminum										
Pointer:	Friction adjust, black, aluminum										
Bourdon Tube:	316L SS C-Shaped (vacuum-600 psi and compound) Helical (800 psi-15,000 psi)										
Socket:	316L SS										
Movement:	300 series SS, polyester segment, overload/underload stops										
Connections:	¼ NPT, lower or lower back										
Connection Code:	<table border="1"> <thead> <tr> <th>Type</th> <th>Code</th> </tr> </thead> <tbody> <tr> <td>¼ NPT</td> <td>O2</td> </tr> <tr> <td>½ NPT</td> <td>O1</td> </tr> <tr> <td>¼" Tube stub</td> <td>JP</td> </tr> <tr> <td>SAE 7/16-20</td> <td>RW</td> </tr> </tbody> </table>	Type	Code	¼ NPT	O2	½ NPT	O1	¼" Tube stub	JP	SAE 7/16-20	RW
Type	Code										
¼ NPT	O2										
½ NPT	O1										
¼" Tube stub	JP										
SAE 7/16-20	RW										

Other connections on application

Ranges:	Vac-15,000 psi and compound
Accuracy:	1.6% full scale <sup>(1)</sup>
Fill Plug:	Ventable
Protection:	Nema 4X/IP65 plug sealed Nema 3/IP54 plug vented

#### OPTIONAL FEATURES

Liquid fill:	Glycerin, silicone (XGV), Halocarbon® (includes throttle plug)
Connections:	Metric and SAE on request
Mounting:	U-clamp (UC), Front flange (FF),
Dials:	Receiver ranges, refrigerant ranges; custom dials

Calibration Cert.:	C4
Oxygen Cleaning:	6B
Throttle Plug:	TU (standard in liquid filled gauge)
Dampened Movement Option:	LL

<sup>(1)</sup> When these gauges are liquid filled the total gauge accuracy may be as much as 2.0%



#### HOW TO ORDER (Typical example)

	DK63	S (L)	O2L	XXX	100#
Dial Size: 63mm (63), 100mm (10)	_____	_____	_____	_____	_____
Tube and Socket Material: 316L SS	_____	_____	_____	_____	_____
Liquid Filled: (glycerin) leave blank if dry	_____	_____	_____	_____	_____
Connection Size: ¼ (O2)	_____	_____	_____	_____	_____
Connection Location: Lower (L), Lower Back (B)	_____	_____	_____	_____	_____
Options: XGV (silicone), XUC (u-clamp), XFF (front flange)	_____	_____	_____	_____	_____
Range: 0/100 psi	_____	_____	_____	_____	_____

### DK63, DK10 SS Case Gauge with SS System

**DK63**  
Lower and Lower Back Connect

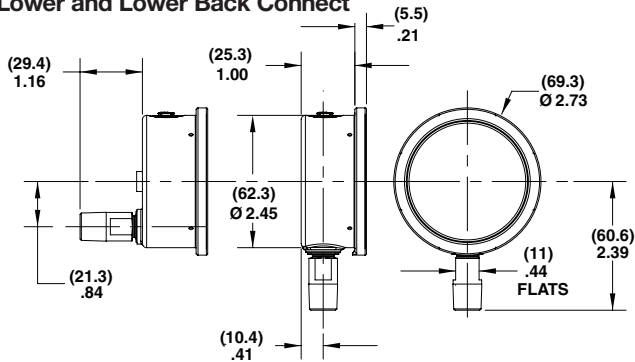

**DK63**  
Lower Back Connect (XUC)

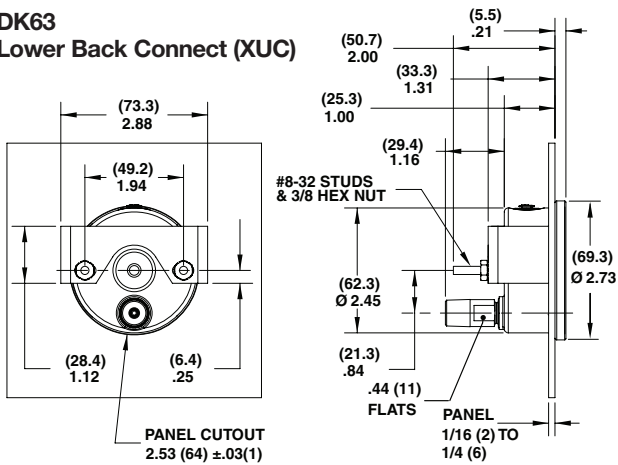

**DK63**  
Lower Back Connect (XFF)

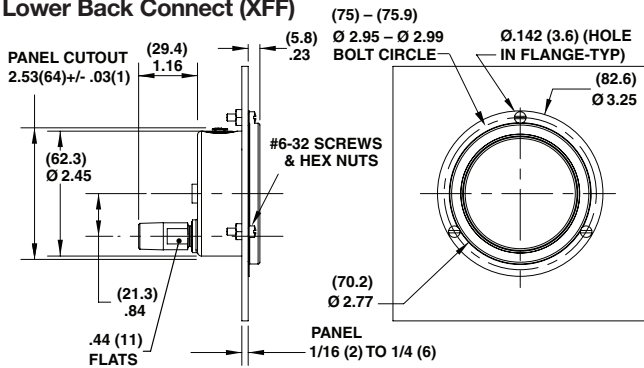

**DK63**  
RW - SAE 7/16 & 20 straight thread

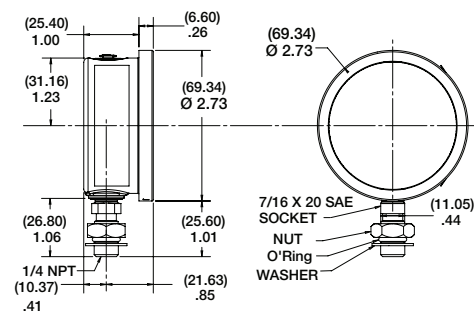

**DK10**  
Lower and Lower Back Connect

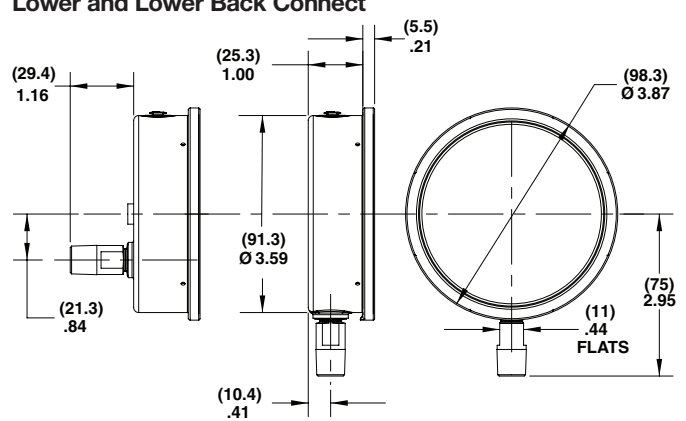

**DK10**  
Lower Back Connect (XUC)

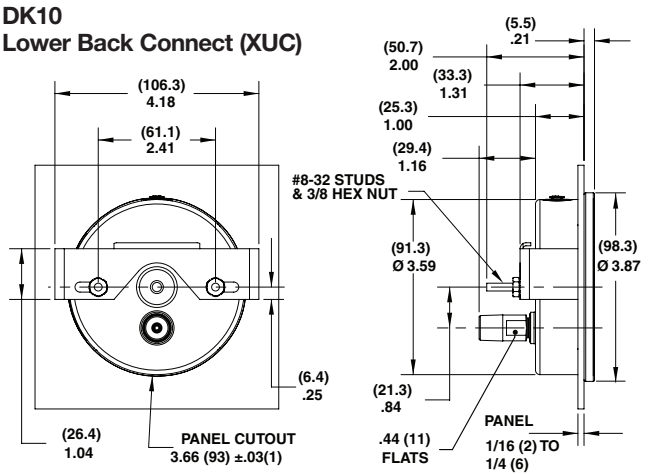

**DK10**  
Lower Back Connect (XFF)

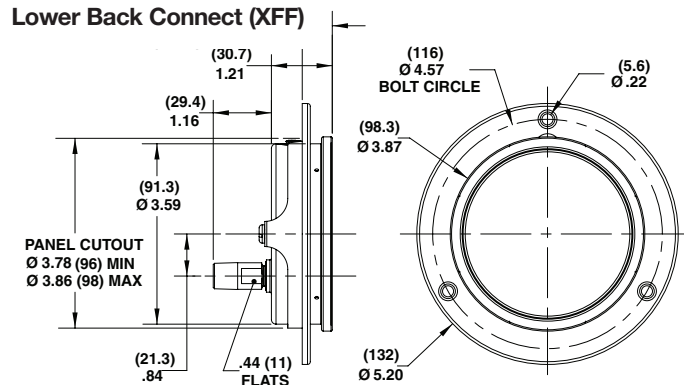

All dimensions in brackets ( ) are millimeters.