

V63 Series for working pressure 300 psig (20.6 bar)

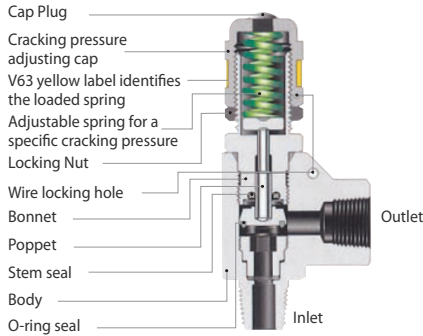

V66 Series for working pressure 6,000 psig (413 bar)

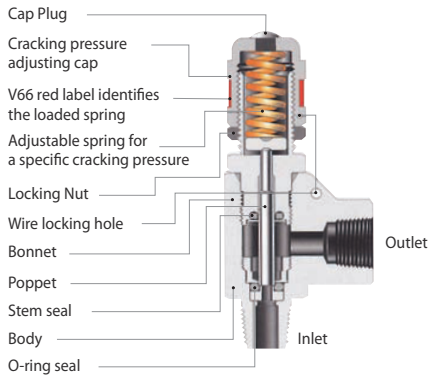

Technical Data

V63 Series Technical Data

- Maximum working pressure : 300 psig @ 68°F (20.6 bar @ 20°C)
- Cracking pressure range : 10 to 225 psig (0.68 to 15.5 bar)

Table 1. V63 Series Spring Designator

Spring Designator	Cracking Pressure		Color Code
	psig	bar	
RVS-L	10 to 225	0.68 to 15.5	YELLOW

- Orifice : 4.8 mm (0.19 in.)

V63/66 Series Temperature Rating

Seal Material	Temperature Rating, °C (°F)	
	V63 Series	V66 Series
FKM (Viton)	-12 ~ -135 (10.4 ~ 275)	-4 ~ 121 (24.8 ~ 250)
Buna N	-23 ~ 148 (-9.4 ~ 298)	-17 ~ 121 (1.4 ~ 250)
Ethylene Propylene (EPDM)	-40 ~ 148 (-40 ~ 298)	-1 ~ 121 (30.2 ~ 250)

V66 Series Technical Data

- Maximum working pressure : 6,000 psig @ 68°F (413 bar @ 20°C)
- Orifice size : 3.4 mm (0.13 in.)
- Cracking pressure range : 50 to 6,000 psig (15.1 to 413 bar)

Table 2. V66 Series Spring Designators

Spring Designator	Cracking Pressure		Color Code	Spring Designator	Cracking Pressure		Color Code
	psig	bar			psig	bar	
RVS-A	50 to 350	3.4 to 24	WHITE	RVS-E	2250 to 3000	155 to 206	GREEN
RVS-B	350 to 750	24 to 51.6	BLUE	RVS-F	3000 to 4000	206 to 275	YELLOW
RVS-C	750 to 1500	51.6 to 103	CLEAR	RVS-G	4000 to 5000	275 to 344	BROWN
RVS-D	1500 to 2250	103 to 155	BLACK	RVS-H	5000 to 6000	344 to 413	ORANGE

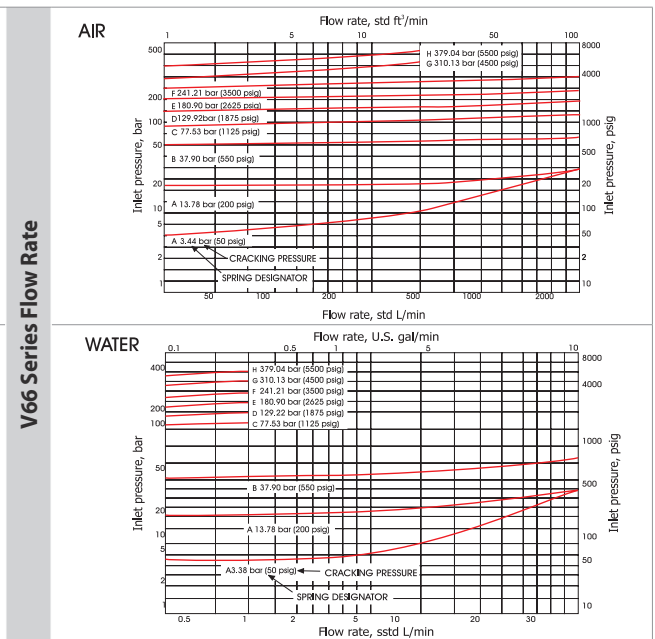
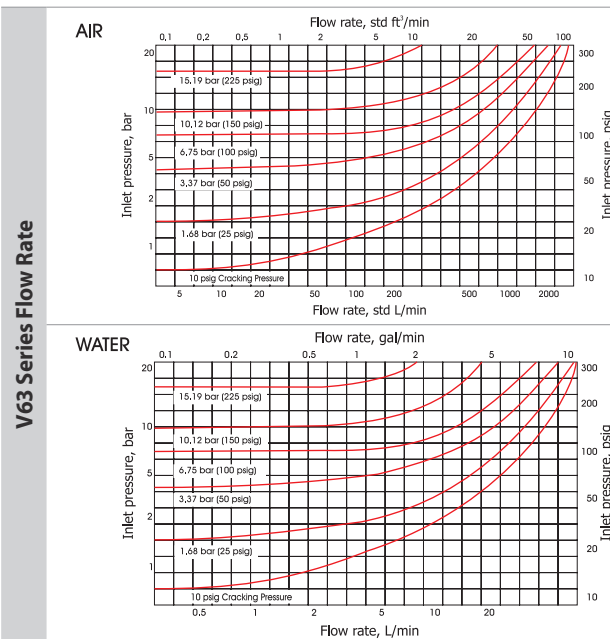

Factory Test

Every valve is factory tested for cracking and reseal performance.



How To Adjust Valve Cracking Pressure

The valve user shall set a specific cracking pressure of the valve supplied.

1. To increase the cracking pressure of the valve, turn the adjusting cap clockwise to compress the spring.
2. To reduce the cracking pressure, turn counterclockwise.
3. Start the pump with the spring relaxed (eight threads showing with the Locking Nut at bottom), with the discharging port open, check the gauge pressure as you turn the adjusting cap clockwise to increase the pressure to the desired operating range.
4. If the system has more than one outlet, set the valve pressure with one outlet open, and then check again with all outlets open to make sure that the set pressure is within the desired operating range.
5. Set the Locking Nut and the wire to maintain the set cracking pressure.

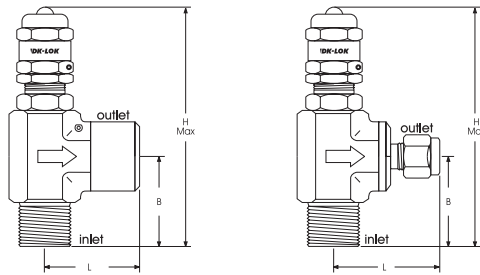

Operation

- Install the valve between the pump outlet as close as possible, and any shut-off device in the discharge line. The preferable mounting position is vertical with the adjusting cap at the top.
- D-Pro relief valve bypasses the system fluid to prevent instrument or sensitive gauge in the system from excess pressure.
- When the inlet pressure overcomes the set spring pressure on the poppet, the poppet lifts off the valve seat, allowing flow to bypass and thereby balance the system pressure.
- If the valve has not been actuated for a period of time, it may initially crack above the set cracking pressure.
- Cracking pressure is only sensitive to inlet pressure, and is not affected by outlet pressure.
- Cv reduction : Valve flow may be reduced by the restriction of pipe and tubing connected.

Material of Construction

Cap Plug	Polypropylene
Adjusting Cap	ASTM A276 / A479 Type 316
Spring	Stainless Steel 302
Locking Nut	ASTM A276 / A479 Type 316
Bonnet	
Poppet	
Stem & O-ring seal	Standard Viton, optional EPDM and Buna N
Body	ASTM A182 F316

Ordering information and Dimensions

Basic Ordering Number	End Connections		Orifice mm (in.)	Dimensions mm (in.)		
	Inlet	Outlet		H	B	L
V63- and V66-	D-4T-	1/4 DK-Lok	V63 : 4.8 (0.19)	100 (3.93)	37 (1.45)	39 (1.53)
	D-6M-	6 mm DK-Lok			38 (1.49)	40 (1.57)
	D-8M-	8 mm DK-Lok		105 (4.13)	44 (1.73)	42 (1.65)
	D-8T-	1/2 DK-Lok			98 (3.85)	36 (1.41)
	D-12M-	12 mm DK-Lok	V66 : 3.4 (0.13)	94 (3.70)		32 (1.25)
	MD-8N8T-	1/2 Male NPT			1/2 DK-Lok	35 (1.37)
	MD-8N12M-	1/2 Male NPT		12 mm DK-Lok		
	MF-4N-	1/4 Male NPT		1/4 Female NPT		
	MF-4R-	1/4 Male ISO 7/1		1/4 Female ISO 7/1		
	MF-6N-	3/8 Male NPT		3/8 Female NPT		
	MF-6R-	3/8 Male ISO 7/1		3/8 Female ISO 7/1		
	MF-8N-	1/2 Male NPT		1/2 Female NPT		
	MF-8R-	1/2 Male ISO 7/1	1/2 Female ISO			



Model Shown :
V66-MF-4N-A

All dimensions shown are for reference only and are subject to change. Dimensions with DK-Lok nuts are in finger-tight position.

How to order

Please select the desired valve basic ordering number, the applicable seal, spring designator and CE certified option from the table below.

Example : V66-D-4T

Seat Designator	Spring Designator	CE certified
Nil : Standard Viton BN : Buna N EP : EPDM	Refer to Table 1, Table 2 for spring designator	CE : valve to 97/23/EC

Factory pressure set valve

To order, specify the set pressure on the valve ordering number.
Example : V66-D-4T-60BAR or V66-D-4T-870PSI

Valve without spring installed

To order, do not specify spring designator on the ordering number.
Example : V66-D-4T

Note : The valve with no spring installed is supplied with the label stated "NO SPRING INSTALLED" on the adjusting cap.

Spring for field assembly

To order, select an applicable spring from the spring designator table 1 & 2. Spring kit includes spring, sticker and wire Example : RVS-A

Safe Valve Selection

The selection of a valve for any application or system design must be considered to ensure safe performance. Valve function, valve rating, material compatibility, proper installation, operation and maintenance remain the sole responsibility of the system designer and the user. DK-Lok accepts no liability for any improper selection, installation, operation or maintenance.