



**Operation**

The spring loaded poppet keeps the valve open position in the normal operation. When an excess flow occurs downstream, the poppet immediately moves to the tripped position to stop rapid release of system fluid.

The valve returns to open position when pressure equalizes through the bleed vent constructed on poppet. The spring in the poppet resets the valve to open position. The least volume of flow goes through the bleed vent that is less than 1% of the valve flow rate while the valve in the tripped position.

Spring-loaded poppet design allows valve for use in vertical, horizontal or in any orientation.

**Factory Test, Cleaning and Packaging**

- Every valve is factory tested for performance in the tripped and open position.
- Valves are cleaned and packaged as per the requirements of DK Tech's product cleaning standard of DC-01.
- Oil free special cleaning and packaging in compliance with ASTM G93 Level C is available on request.

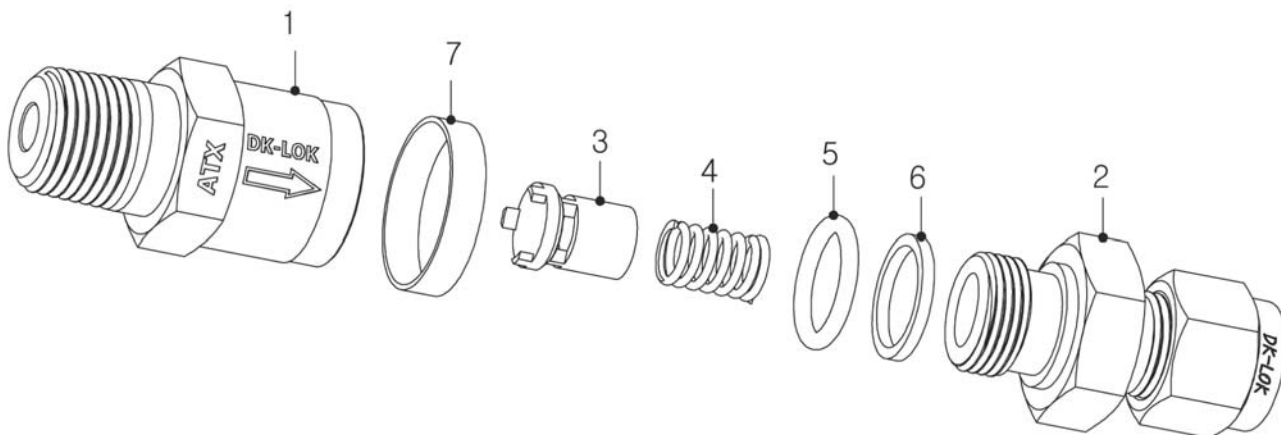

**Materials of Construction**

Component	Material
* 1. Body	SS316/ASTM A276 or ASTM A479
* 2. Connector	
* 3. Poppet	
* 4. Spring	SS302/ASTM A313
* 5. O-ring	Standard FKM O-ring Optional NBR, EPDM, and FFKM
6. Backup ring	Standard PTFE / ASTM D1710 Optional PEEK
7. Indicator ring	Red-color anodized Aluminium

\* Wetted parts and lubricants listed in blue.



**VX36 Series Flow Rate @ 70 °F (20 °C)**

The valve stops rapid release of system fluid if a line rupture or similar thing occurs on the downstream by poppet's tripping into the metal seat position when flow volume through the valve increases to a set value.

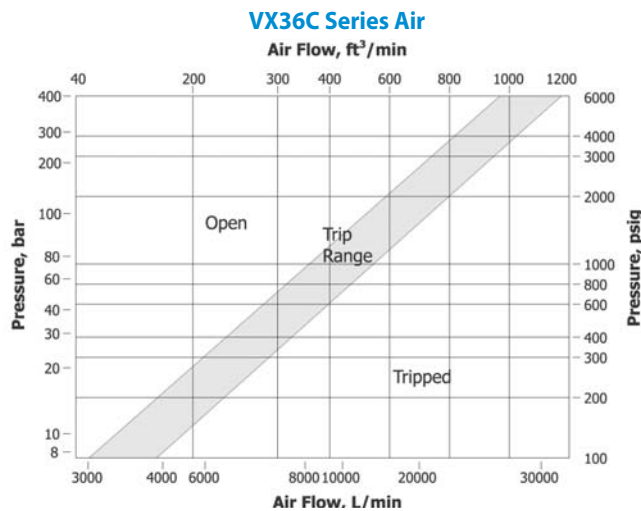
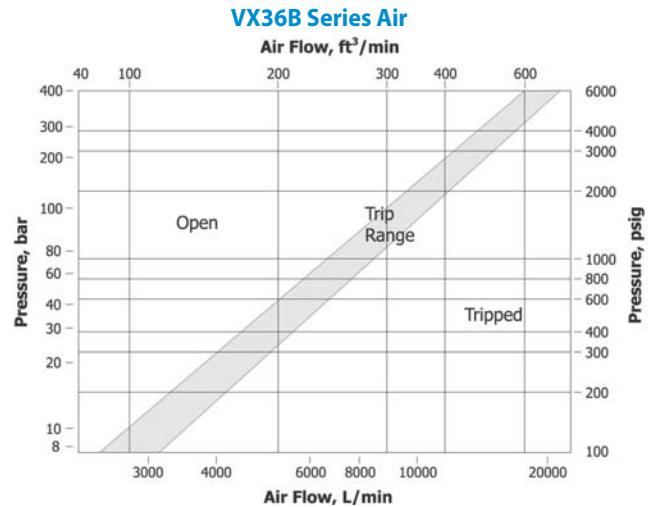
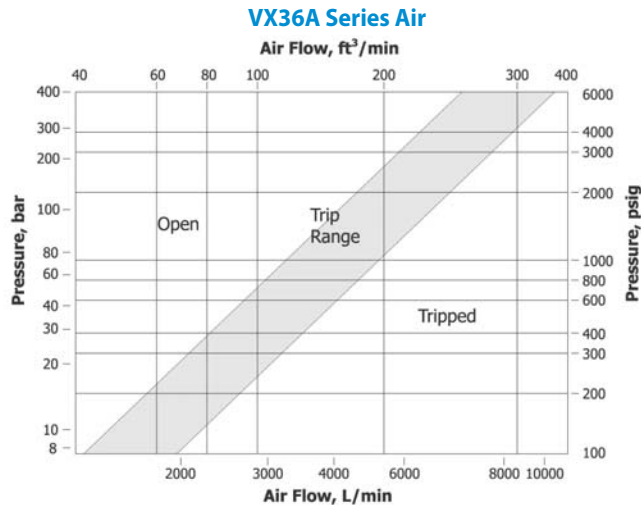

**VX36A, B,C Series Water**

Series	Cv	Trip Range U.S. gal/min (L/min)
VX36A	0.5	3.9 to 5.8 (14.7 to 21.9)
VX36B	1.1	8.2 to 10.0 (31.0 to 37.8)
VX36C		11.2 to 14.9 (42.3 to 56.3)

**Pressure-Temperature Ratings**

- Rating based on valve with standard FKM O-Ring.

ASME Class / Material Group	2500 / 2.2
Material	Stainless Steel 316
Temp. °F(°C)	Working Pressure psig (bar)
-10 (-23)~100 (37)	6,000 (413)
200 (93)	5,160 (355)
250 (121)	4,910 (338)
300 (148)	4,660 (321)
400 (204)	4,280 (294)

**Optional O-ring Materials**

- FKM O-Rings are standard. Add the designator to the ordering number for valve with optional O-ring material.

O-ring Materials	Designator	Temperature Rating °F(°C)
FKM	Nil	-10 ~ 400 (-23 ~ 204)
NBR	BN	-4 ~ 221 (-20 ~ 105)
EPDM	EP	-50 ~ 300 (-45 ~ 148)
FFKM	KZ	-10 ~ 400 (-23 ~ 204)

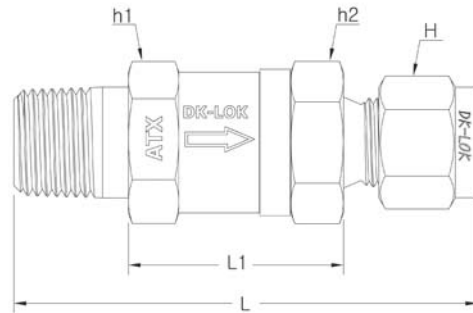

Ordering Information and Dimensions

Basic Ordering Number	End Connections		Pressure Rating @ 100°F (37°C), psig(Bar)	Cv	Dimensions, mm (in.)					
	Inlet	Outlet			L	L1	H	h1	h2	
VX36A-	D-4T-	1/4 in. DK-Lok	6000 (413)	0.5	61.7 (2.43)	26.4 (1.04)	9/16 in.	11/16 in.		
	D-6M	6 mm DK-Lok	6000 (413)		61.7 (2.43)	26.4 (1.04)	14 mm	11/16 in.		
	M-2N-	1/8 in. Male NPT	6000 (413)		45.5 (1.79)	26.4 (1.04)	-	11/16 in.		
	F-2N-	1/8 in. Female NPT	6000 (413)		47.5 (1.87)	-	-	11/16 in.		
	M-4N-	1/4 in. Male NPT	6000 (413)		55.1 (2.17)	26.4 (1.04)	-	11/16 in.		
	M-4R-	1/4 in. Male PT	6000 (413)		55.1 (2.17)	26.4 (1.04)	-	11/16 in.		
	F-4N-	1/4 in. Female NPT	6000 (413)		54.1 (2.13)	-	-	11/16 in.		
	MD-4N4T-	1/4 in. Male NPT	1/4 in. DK-Lok		6000 (413)	58.4 (2.3)	26.4 (1.04)	9/16 in.	11/16 in.	
	MF-4N	1/4 in. Male NPT	1/4 in. Female NPT		6000 (413)	54.6 (2.15)	-	-	11/16 in.	
VX36B-	D-6T-	3/8 in. DK-Lok	6000 (413)	1.1	69.9 (2.75)	31.2 (1.23)	11/16 in.	1 in.		
	D-8M	8 mm DK-Lok	6000 (413)		68.6 (2.70)	31.2 (1.23)	16 mm	1 in.		
	M-6N-	3/8 in. Male NPT	6000 (413)		59.9 (2.36)	31.2 (1.23)	-	1 in.		
	F-6N-	3/8 in. Female NPT	5300 (365)		64.8 (2.55)	-	-	1 in.		
	MD-6N6T-	3/8 in. Male NPT	3/8 in. DK-Lok		6000 (413)	64.9 (2.56)	31.2 (1.23)	11/16 in.	1 in.	
	MF-6N-	3/8 in. Male NPT	3/8 in. Female NPT		5300 (365)	62.4 (2.45)	-	-	1 in.	
VX36C-	D-8T-	1/2 in. DK-Lok	6000 (413)	1.1	75.2 (2.96)	31.2 (1.23)	7/8 in.	1 in.		
	D-12M-	12 mm DK-Lok	6000 (413)		75.2 (2.96)	31.2 (1.23)	22 mm	1 in.		
	M-8N-	1/2 in. Male NPT	6000 (413)		69.3 (2.73)	31.2 (1.23)	-	1 in.		
	M-8R-	1/2 in. Male PT	6000 (413)		69.6 (2.74)	31.2 (1.23)	-	1 in.		
	F-8N-	1/2 in. Female NPT	4900 (337)		77.0 (3.03)	-	-	1-1/16 in.		
	F-8R-	1/2 in. Female PT	4900 (337)		83.6 (3.29)	-	-	1-1/16 in.		
	MD-8N8T-	1/2 in. Male NPT	1/2 in. DK-Lok		6000 (413)	72.6 (2.86)	31.2 (1.23)	7/8 in.	1 in.	
	MF-8N-	1/2 in. Male NPT	1/2 in. Female NPT		4900 (337)	69.7 (2.53)	-	-	1 in.	1-1/16 in.

All dimensions shown are for reference only and subject to change. Dimensions with DK-Lok are in finger-tight position.

How to order

Select valve basic ordering number, applicable options, and body material.

<b>VX36A-D-4T-</b>	<b>BN-</b>				<b>S</b>
<b>VX36A-D-4T-</b>		<b>EP-</b>			
<b>VX36C-D-8T-</b>			<b>KZ-</b>	<b>PK-</b>	
<b>O-ring Material Designator</b>		<b>Backup Ring</b>		<b>Valve Body Material Designator</b>	
Nil : FKM BN : NBR EP : EPDM KZ : FFKM (Kalrez)		Nil : PTFE PK : PEEK		S : 316 stainless steel	

Safe Valve Selection

The selection of a valve for any application or system design must be considered to ensure safe performance. Valve function, valve rating, material compatibility, proper installation, operation and maintenance remain the sole responsibility of the system designer and the user. DK-Lok accepts no liability for any improper selection, installation, operation or maintenance.