



# VC34 Series CNG Check Valves

VC34-1



### Features

- High Flow check valve.
- Bar stock two piece study design.
- Poppet O-ring secured on groove provides leak-tight seal.
- Unidirectional flow control of fluids
- Prevent loss of media caused by failed connections.

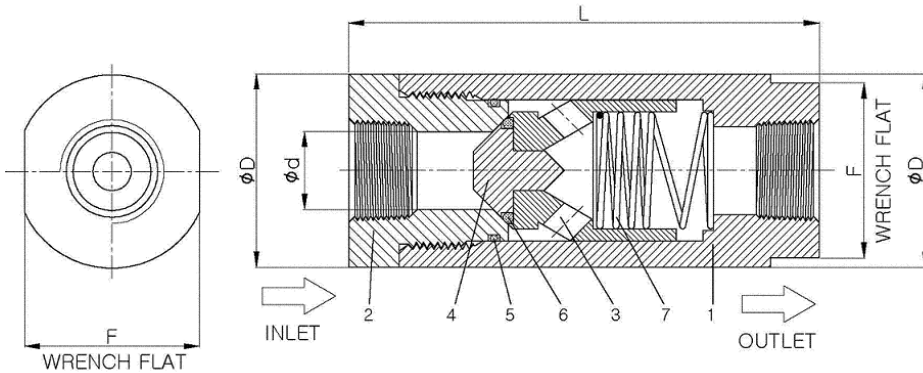

### Materials of Construction

No.	Component	Material	Q'ty
1	Body	SS 316	1
2	Connector	SS 316	1
3	Poppet	SS 316	1
4	Poppet Cap	SS 316	1
5	O-Ring	HNBR	1
6	O-Ring	HNBR	1
7	Spring	SS 304	1

### Technical Data

**Flow Rate:** 2090 SCFM (3551 Nm<sup>3</sup>/hr)  
**Working Pressure:** 3600 psi (248 bar)  
**Burst Pressure:** 25 000 psi (1724 bar)  
**Temperature Range:** - 40 to 120 C (-40 to 250 F)

### Ordering Number and Dimensions

Ordering Number	End Connections		Dimension in.(mm)			
	Inlet	Outlet	D	d	L	F
VC34-F16N-S	1" Female NPT		2.48 (63)	1 (25.4)	6.04 (153.5)	2.24 (57)
VC34-F16R-S	1" Female ISO 7-1					

### Factory Test, Cleaning and Packaging

Every valve is factory tested for cracking and reseal performance and cleaned, packaged in accordance with DK-LOK cleaning standard of DC-01.